

LPMS-CU3



LPMS Wired Miniature Motion Sensor / IMU / AHRS with CAN Bus and USB Connectivity

The LPMS-CU3 is an innovative and high performance miniature motion sensor. Integrating CAN Bus and USB interfaces into one unit, the LPMS-CU3 perfectly fits to both machine and human motion measurements for size and cost sensitive applications.



Key Features

- MEMS miniature inertial measurement unit (IMU)
- Integration of 3-axis gyroscope, accelerometer, magnetometer, temperature and barometric pressure sensor in one unit
- Real-time, on-device calculation of sensor orientation, linear acceleration and altitude
- Data output rates of up to 500Hz
- Variety of wired interfaces: CAN Bus and USB
- Control applications and SDK for Windows, Linux

Applications

- Manipulator balance control
- Driving navigation
- Racing car status monitoring
- Robot arm control

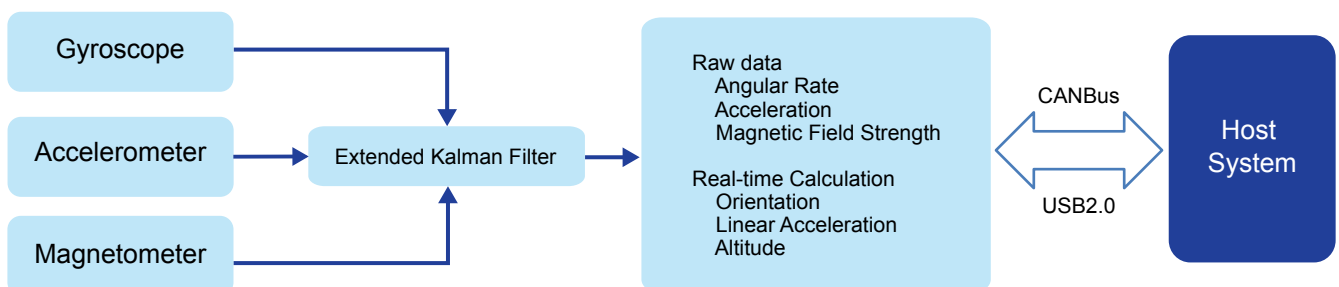

Sensor Specifications

Sensor Model	LPMS-CU3	
Dimensions	34×34.5×15.7mm	
Weight	17.6g	
Communication Interfaces	CAN Bus	USB
Max. Baudrate	1Mbit/s	921.6Kbit/s
Communication Protocol	CANopen / Sequential CAN	LP-BUS
Orientation Range	Roll: ±180°; Pitch: ±90°; Yaw: ±180°	
Resolution	0.01°	
Accuracy	< 0.5° (Static), < 2°RMS (Dynamic)	
Accelerometer	3-axis, ±2 / ± 4 / ± 8 / ± 16 g, 16bits	
Gyroscope	3-axis, ± 125 / ± 250 / ± 500 / ± 1000 / ± 2000dps / ± 4000dps, 16bits	
Magnetometer	3-axis, ± 2 / ± 8 gauss, 16bits	
Pressure Sensor	300-1100 hPa	
Data Output Format	Raw & Calibrated data, Euler Angle, Quaternion, Linear Acceleration	
Data Output Rate	500Hz	
Current Draw	~21mA	
Power Supply	5V ~ 18V DC	5V DC
Connector	Micro USB-B	DB9 female
Case Material	ABS	
Operating Temperature	-40~+80°C	
Software & Driver	LpmsControl2 interface software (Windows), Open source sensor driver for Windows and Linux (OpenZen, supports C, C++, Python, C#, Unity, ROS)	



Mechanical Drawing

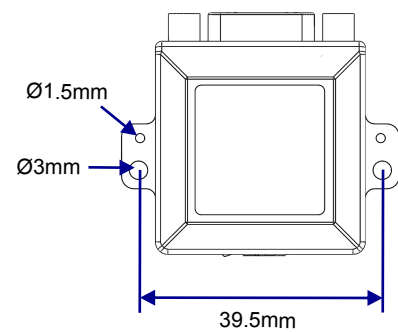
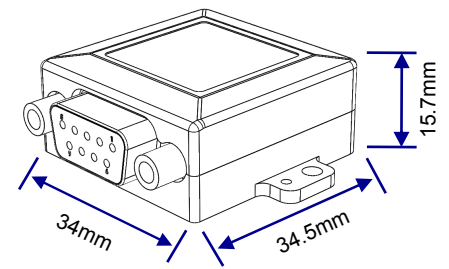

Package

- LPMS-CU3 Sensor x 1
- User guide card x1
- Cable x1
- Box x1
- Warranty (1 Year)



Interface Software

